

Sit and surf.

Industrial Style L-Shaped Desk Smoked Oak

Model 5425077

Table of Contents

Assembly Tools Required

Part Identification	3
Hardware Identification	3
Assembly Steps	4-8
Français	9-10
Español	11-12
Safety	13-14
Warranty	15

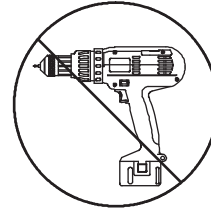

Skip the power trip.
This time.

Part Identification

Now you know
our ABCs.



⚠ While not all parts are labeled, some of the parts will have a label or an inked letter on the edge to help distinguish similar parts from each other. Use this part identification to help identify similar parts.

A	LARGE TOP (1)
B	SMALL TOP (1)
C	SHELF (2)
D	CENTER LEG (1)
E	LEFT LEG (1)
F	RIGHT LEG (1)
G	BRACE (1)
H	TIE PLATE (1)

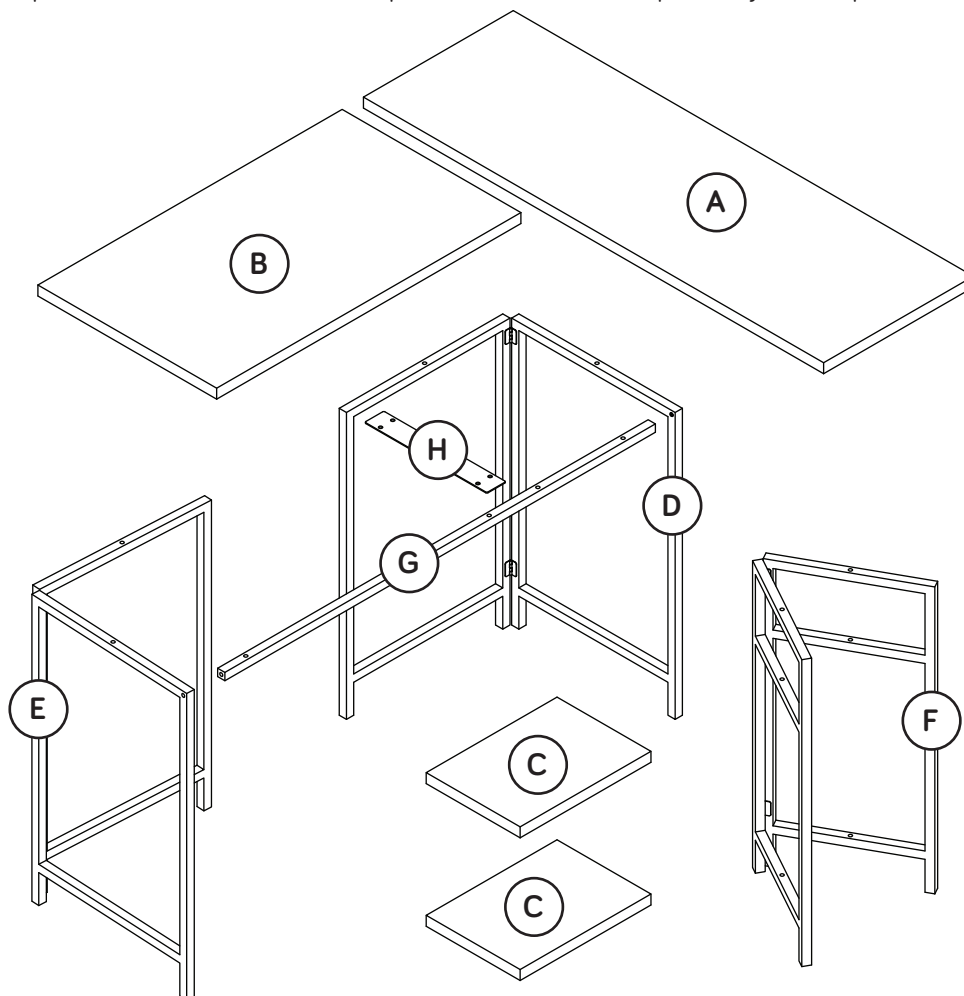

Hardware Identification

⚠ Screws are shown actual size. You may receive extra hardware with your unit.

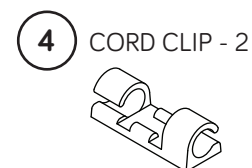
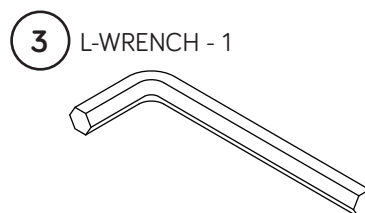

Step 1

- ✚ Assemble your unit on a carpeted floor or on the empty carton to avoid scratching your unit or the floor.
- ✚ Fasten the RIGHT LEG (F) to the LARGE TOP (A). Use two LONG THUMB SCREWS (1).

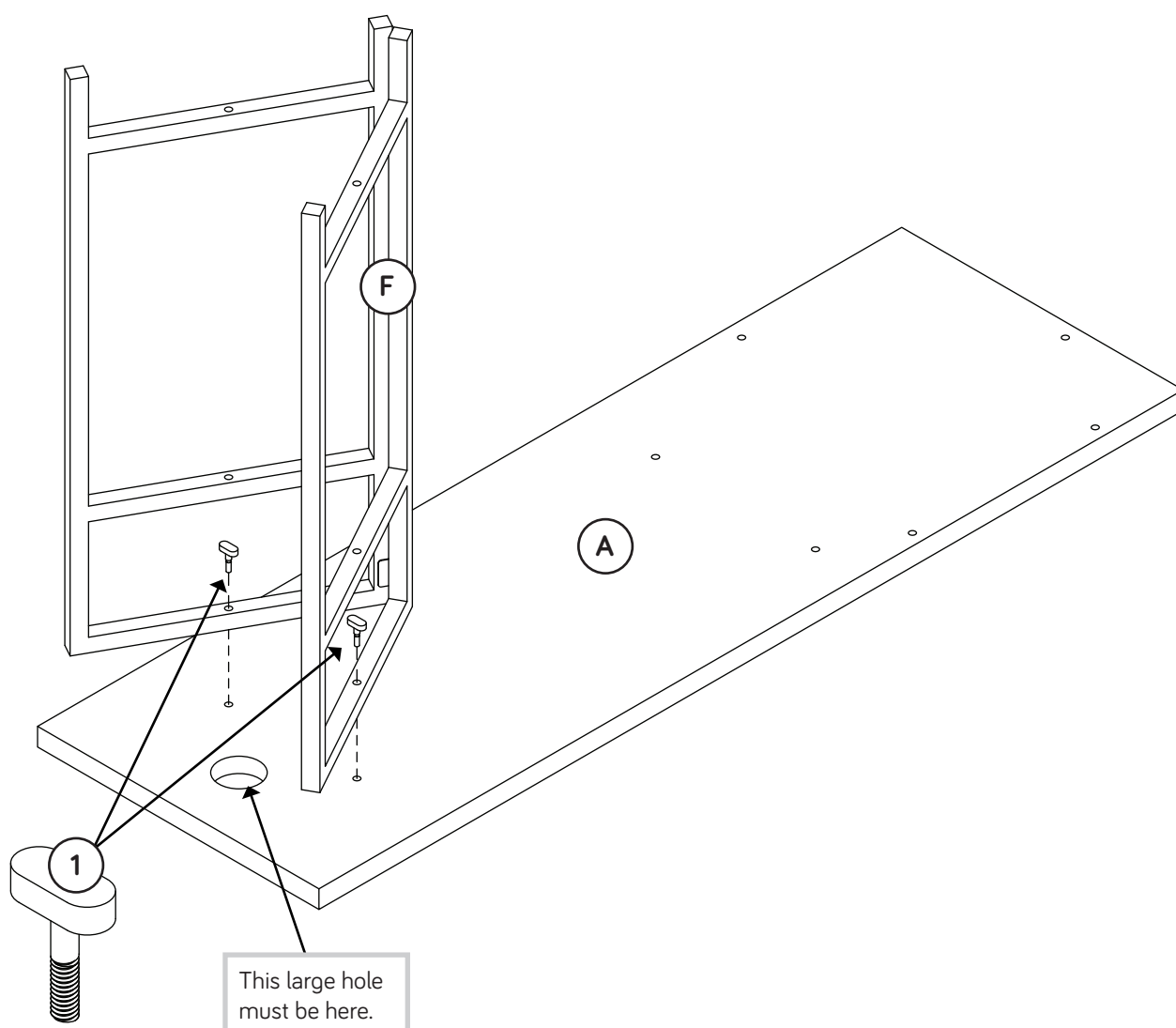

Step 2

- Fasten the SHELVES (C) to the RIGHT LEG (F). Use four LONG THUMB SCREWS (1).

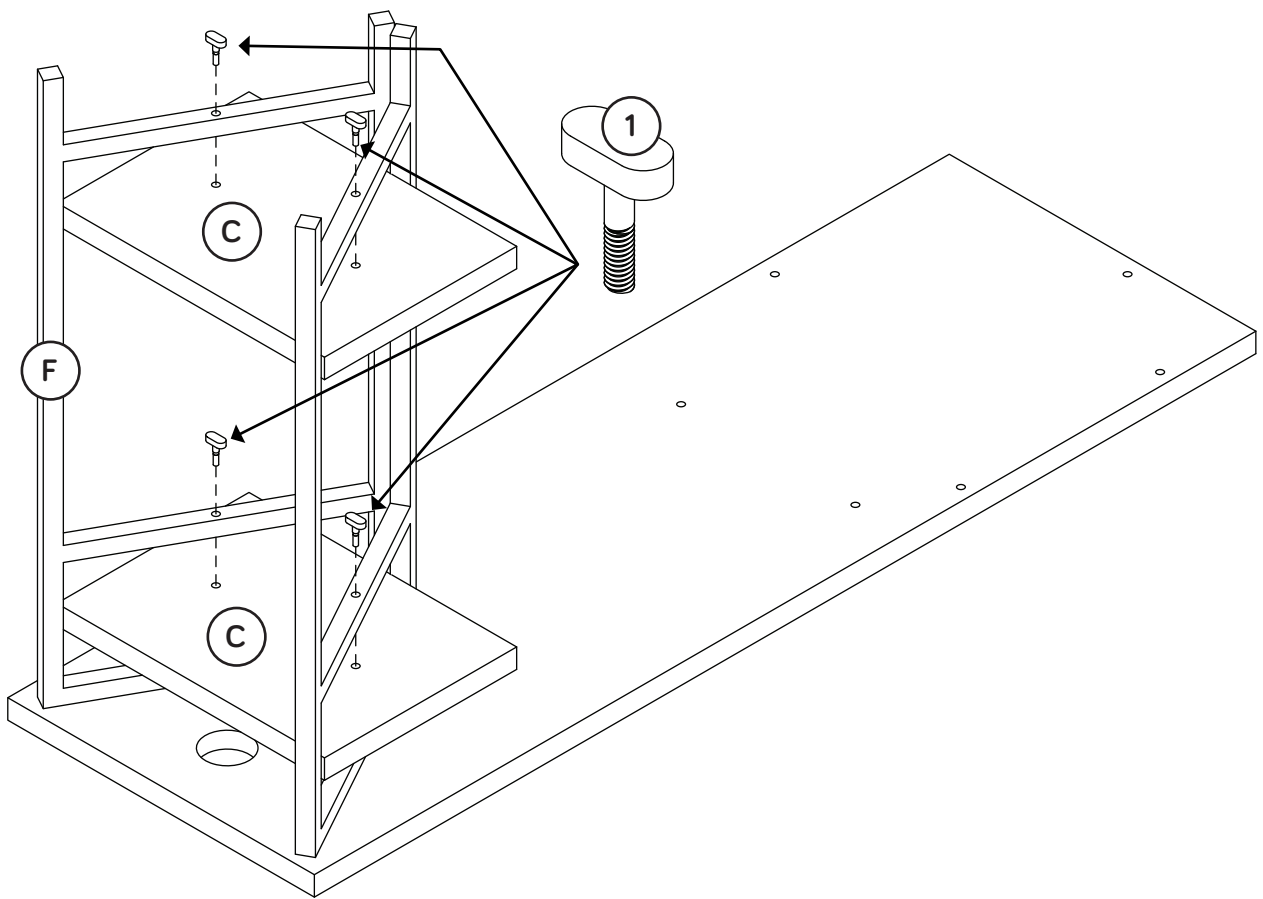

Step 3

- ✚ Fasten the TIE PLATE (H) to the TOPS (A and B). Use four SHORT THUMB SCREWS (2).
- ✚ Place the CENTER LEG (D), LEFT LEG (E) and BRACE (G) onto the TOPS (A and B) as shown in the lower diagram.
- ✚ Fasten the BRACE (G) to the CENTER LEG (D) and LEFT LEG (E). Turn two BLACK 1-3/16" HEX HEAD SCREWS (5) with the L-WRENCH (3).
- ✚ **NOTE:** You will fasten the BRACE and LEGS to the TOP in the next step.

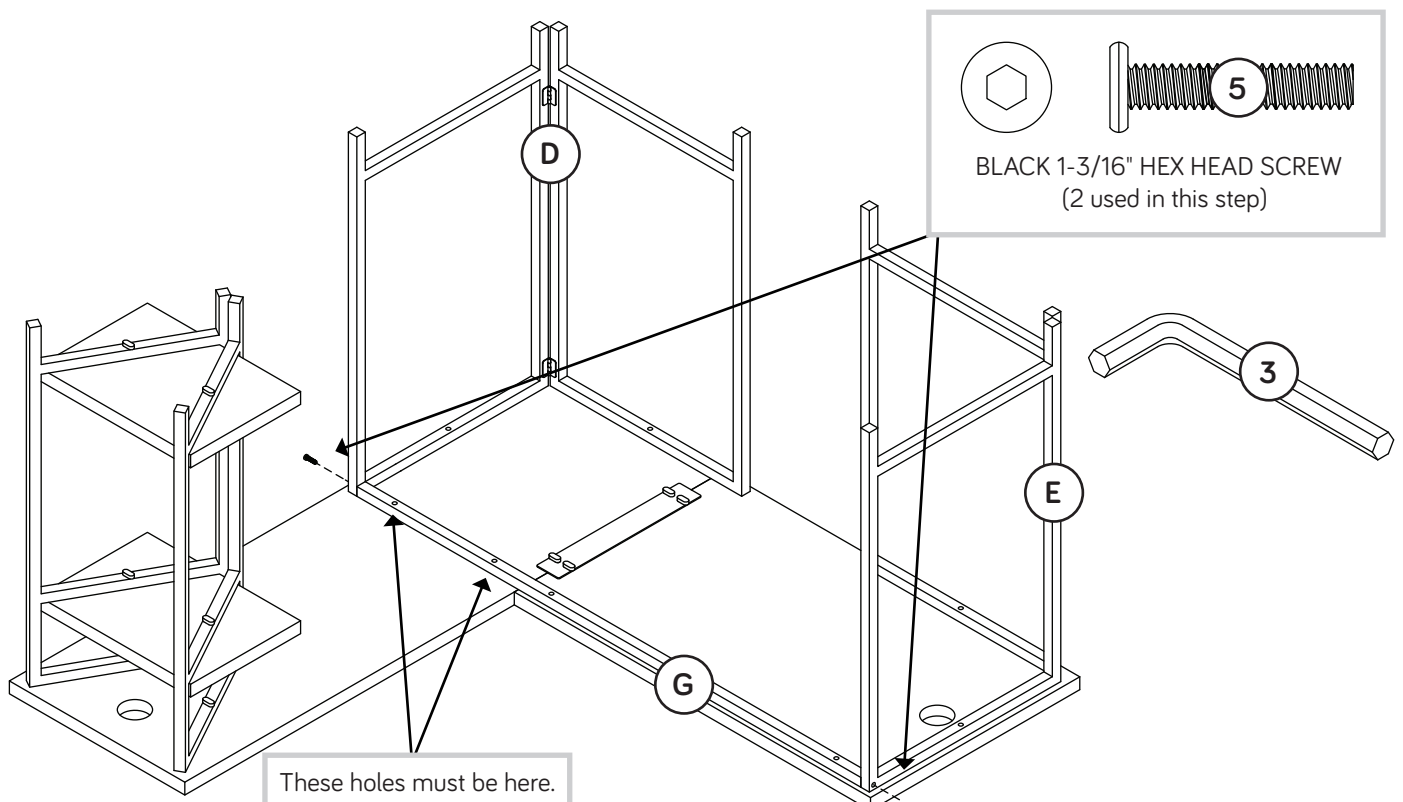
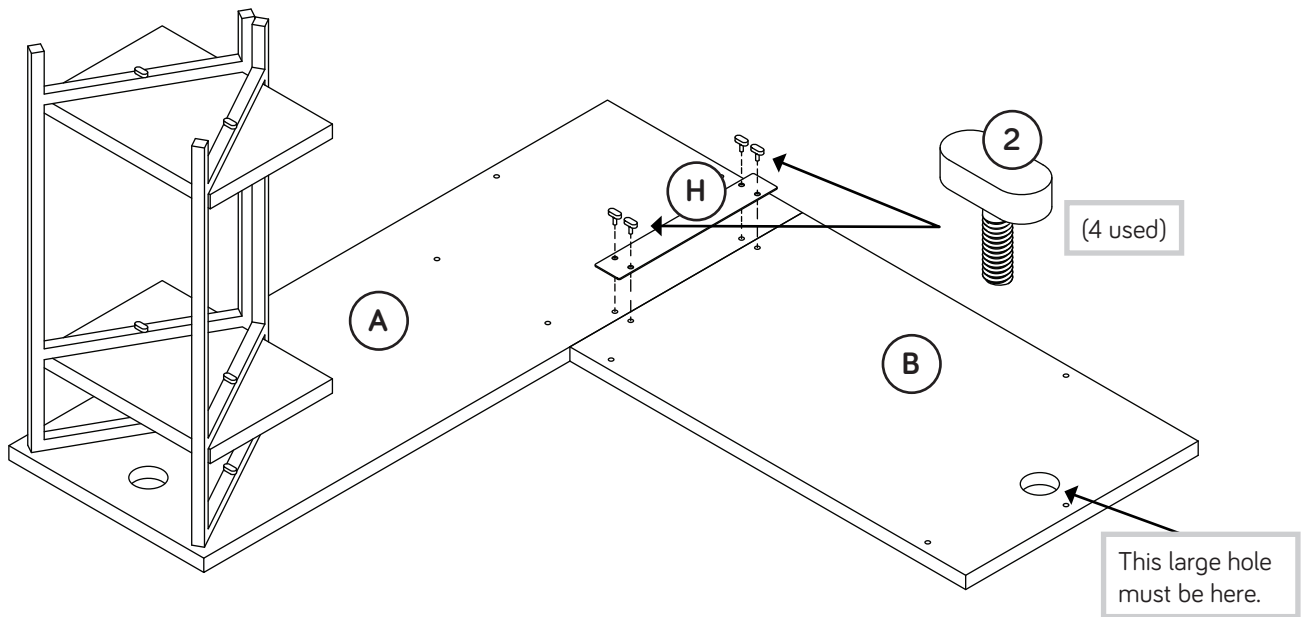

Step 4

- ✚ NOTE: Start each LONG THUMB SCREWS (1) a few turns before completely tightening all of them.
- ✚ Fasten the CENTER LEG (D) to the LARGE TOP (A). Use two LONG THUMB SCREWS (1).
- ✚ Fasten the BRACE (G) to both TOPS (A and B). Use four LONG THUMB SCREWS (1).
- ✚ Fasten the LEFT LEG (E) to the SMALL TOP (B). Use two LONG THUMB SCREWS (1).
- ✚ Now, tighten all LONG THUMB SCREWS (1).
- ✚ Peel the backing from the CORD CLIP (4) and stick them on the bottom surface of the TOPS (A and B) where you prefer.

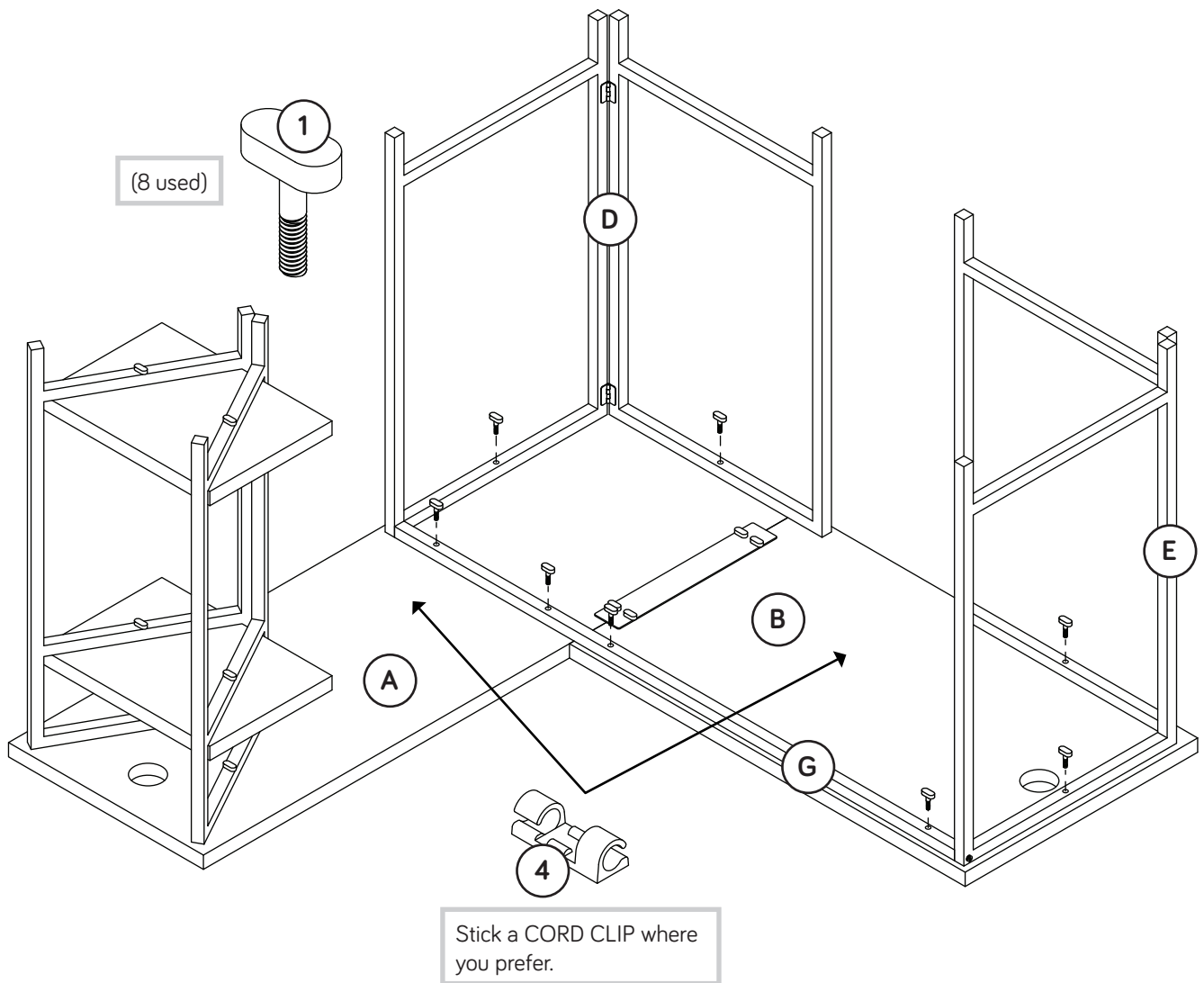

Step 5

- ✚ With another person's help, stand your L-Desk upright.
- ✚ NOTE: Please read the back pages of the instruction booklet for important safety information.
- ✚ This completes assembly. Clean with a damp cloth. Wipe dry.

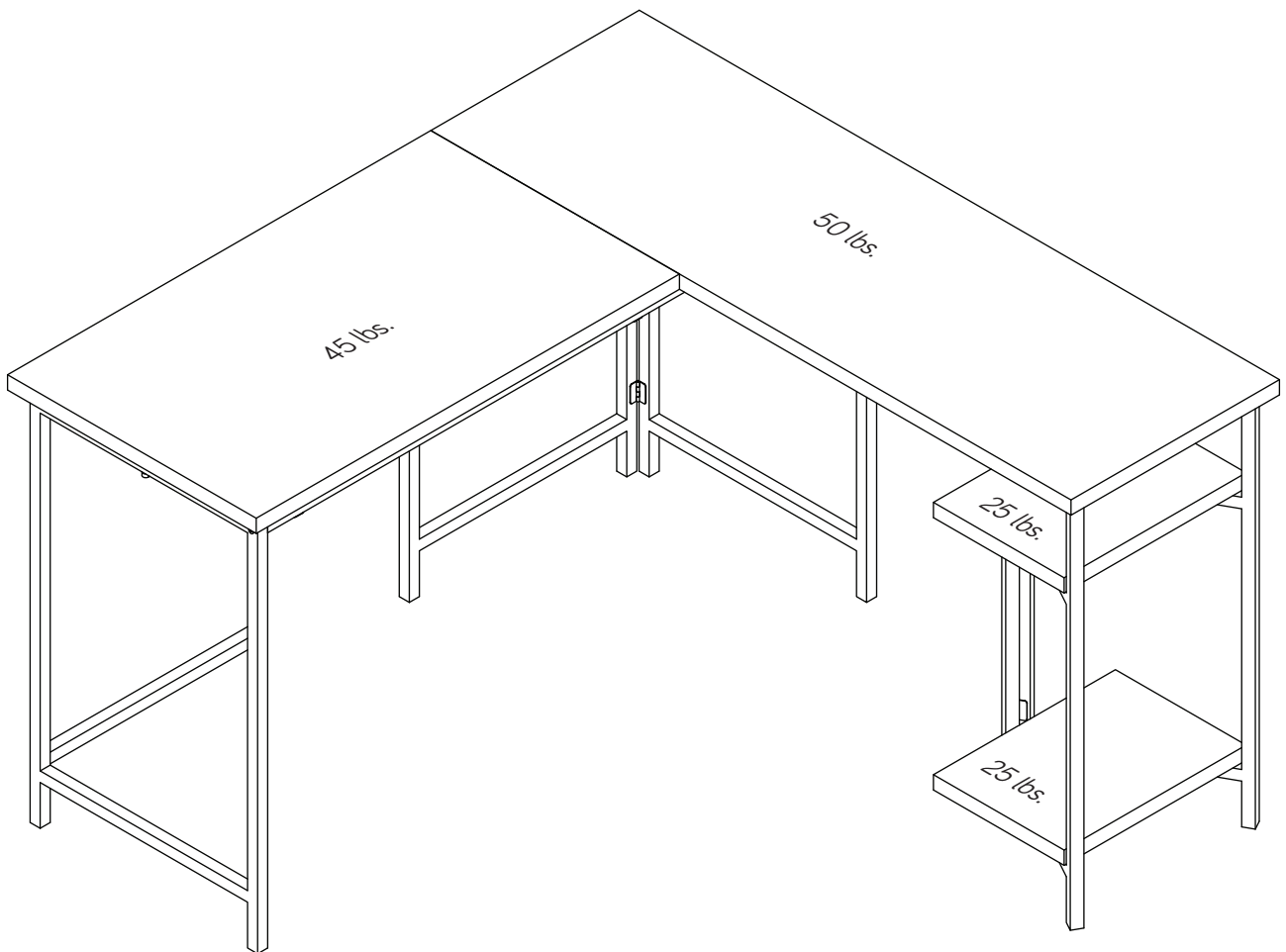

⚠ WARNING

Please use your furniture correctly and safely. Improper use can cause safety hazards, or damage to your furniture or household items. ***Carefully read the following chart.***

Look out for:	What can happen:	How to avoid the problem:
<ul style="list-style-type: none">• Overloaded shelves or drawers.• Improper loading can cause the product to be top-heavy.	<ul style="list-style-type: none">• Risk of injury.• Top-heavy furniture can tip over.• Overloaded shelves and drawers can break.	<ul style="list-style-type: none">• Never exceed the weight limits shown in the instructions.• Work from bottom to top when loading shelves and drawers. Place the heavier items on the lower shelves or in lower drawers.
<ul style="list-style-type: none">• Improperly moving furniture that is not designed and equipped with casters.	<ul style="list-style-type: none">• Furniture can tip over or break if improperly moved.• Physical injury. Furniture can be very heavy.• Breakage of tops - particularly with double pedestal furniture (drawers at both ends).	<ul style="list-style-type: none">• Unload shelves and drawers from top to bottom before moving the unit.• Do not push furniture, especially on a carpeted floor. Have a friend help you lift the item and set it in place.• Provide support to the center section of the top when lifting the furniture.
<ul style="list-style-type: none">• Placing TVs on furniture items that are not designed to support a television is hazardous.	<ul style="list-style-type: none">• Risk of injury or death. TVs can be very heavy. Plus the weight and location of the picture tube tends to make TVs unbalanced and prone to tipping forward.	<ul style="list-style-type: none">• This product is not designed to support a television.