

# TIMBER ART DESIGN UK

**DR 960006**

## ASSEMBLY INSTRUCTIONS

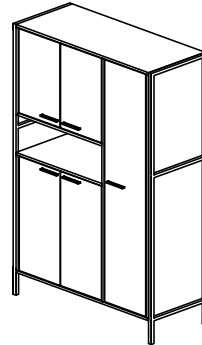

**IMPORTANT**

**PLEASE READ BEFORE YOU CONTINUE FURTHER**

### WARNING AND INSTRUCTIONS

- PLEASE KEEP THE ORIGINAL PACKAGING UNTIL THE ITEM IS FULLY ASSEMBLED AND IN PLACE. IN THE UNLIKELY EVENT THAT YOU NEED TO RETURN YOUR PRODUCT, IT MUST BE RETURNED IN ITS ORIGINAL PACKAGING TO AVOID FURTHER DAMAGE. FAILURE TO COMPLY TO THESE PROCEDURES, NO RETURN'S WILL BE ACCEPTED.
- IMPORTANT: RETAIN THESE INSTRUCTIONS FOR FUTURE REFERENCE.
- DUE TO THE SIZE OF THIS PRODUCT WE RECOMMEND THAT IT IS ASSEMBLED IN THE ROOM INTENDED FOR USE.
- WHEN YOU ARE READY TO START, MAKE SURE THAT YOU HAVE THE RIGHT TOOLS, PLENTY OF SPACE AND A CLEAN, DRY AREA FOR ASSEMBLY.
- UNWRAP ALL PACKAGING MATERIALS AND PLACE THE COMPONENTS ON TOP OF THE CARTON BOX OR ON A CLEAN FLOOR TO PREVENT IT FROM SCRATCHING.
- CHECK THE PACK AND MAKE SURE YOU HAVE ALL THE PARTS LISTED.
- ENSURE THAT THIS PRODUCT IS FULLY ASSEMBLED AS ILLUSTRATED BEFORE USE.
- TOOLS NOT INCLUDED.
- CHECK ALL SCREWS OR BOLTS ARE TIGHTENED AND INSPECT REGULARLY.
- THIS PRODUCT SHOULD ONLY BE USED ON FIRM LEVEL GROUND.
- KEEP SMALL PART OUT OF REACH OF CHILDREN.
- MAKE SURE THE LEGS REMAIN IN CONTACT WITH THE GROUND.
- DO NOT USE POWER TOOLS TO CONSTRUCT THIS PRODUCT.
- DO NOT TIGHTENED SCREWS UNTIL FULLY ASSEMBLED.
- DO NOT OVER TIGHTENED SCREWS OR BOLTS.
- DO NOT USE THIS PRODUCT IF PARTS ARE MISSING, DAMAGE OR WORN.
- DO NOT SIT AND STAND ON THE PRODUCT.
- TO CLEAN WIPE WITH A SPONGE AND WARM SOAPY WATER. DO NOT USE SOLVENT BASED CLEANERS OR DETERGENTS AS THEY CAN BLEACH OR DAMAGE THE PRODUCT.
- NEVER USE SCOURERS, ABRASIVES OR CHEMICAL CLEANERS.

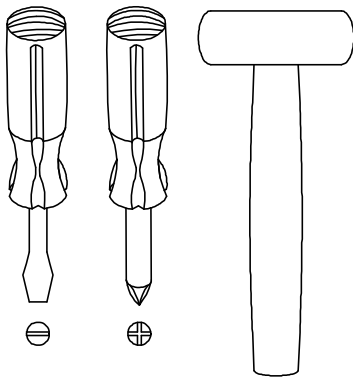

(Tools not provided)

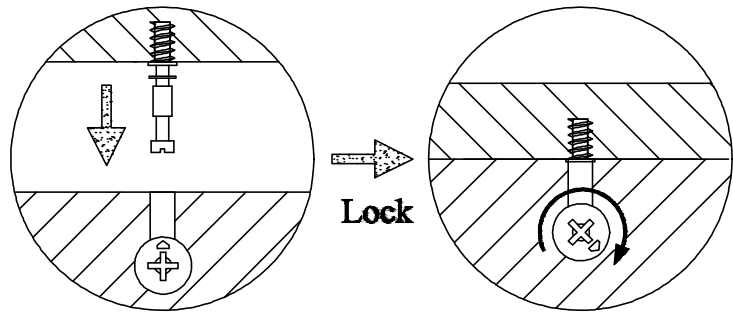

Use a flat blade screwdriver to tighten the cam nuts. A quarter turn clockwise is all that is needed.

## This is how a cam nut works.....

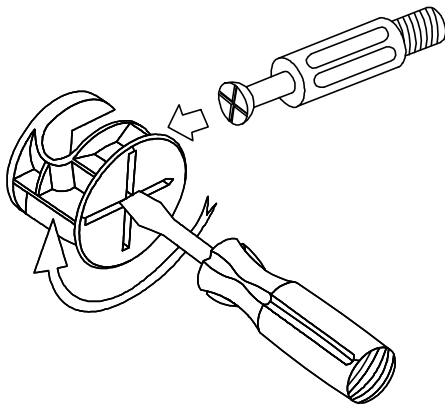

The head of the cam bolt goes into the open mouth of the cam nut. You then turn the cam nut so it tightens over the bolt.

### TWO PERSONS REQUIRED TO ASSEMBLE THIS PRODUCT



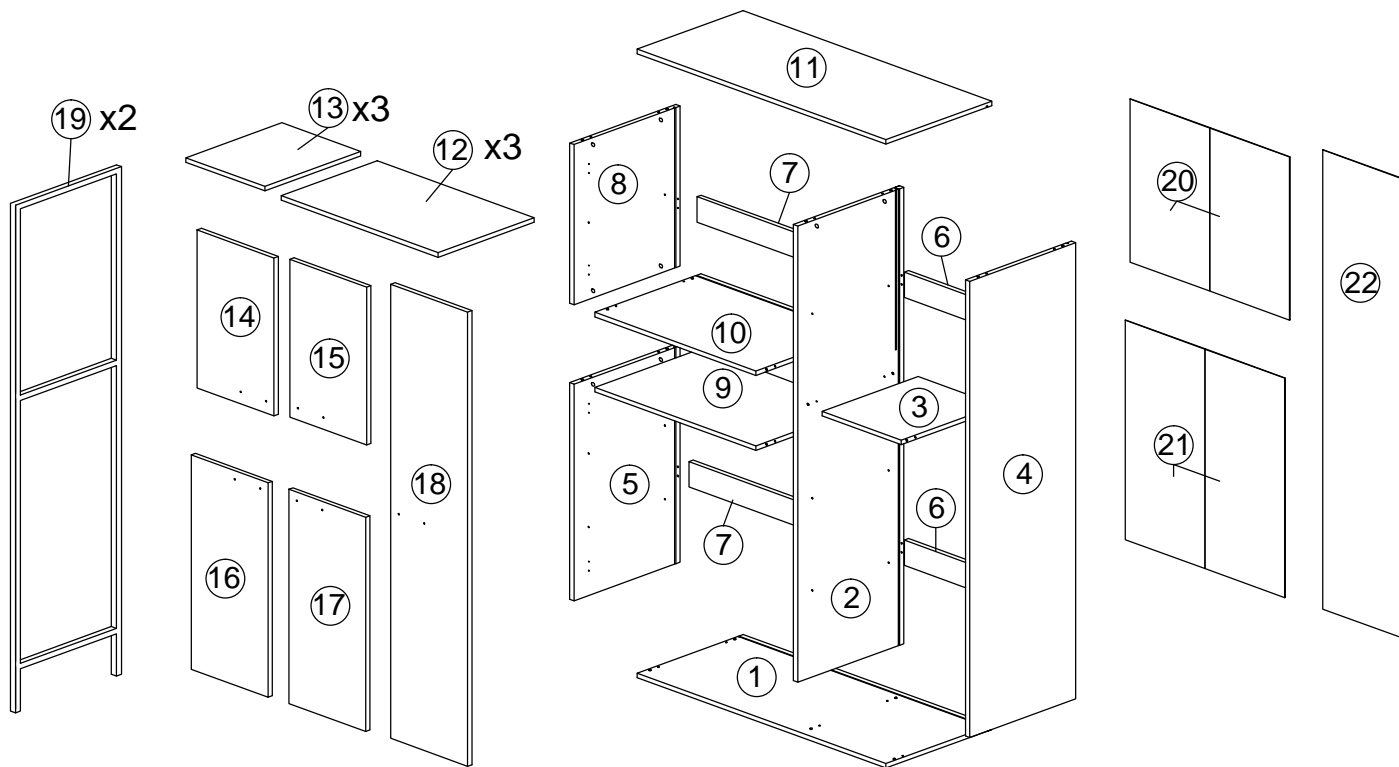













1. Please check that you have all the parts listed before you start assembling. If you do find that something is missing, do not continue assembly. Please contact your supplier immediately.
2. Lay out all of the components on a soft surface as if you were preparing to do a jigsaw puzzle.
3. Separate and identify each component from the hardware pack and rest each one in its proper location before fastening.



## PARTS LIST (1/2)

NO.	PARTS					QTY
1	938	X	400	X	15	1 PC
2	1618	X	399	X	15	1 PC
3	298	X	362	X	15	1 PC
4	1618	X	399	X	15	1 PC
5	768	X	399	X	15	1 PC
6	298	X	90	X	15	2 PCS
7	592	X	90	X	15	2 PCS
8	568	X	399	X	15	1 PC
9	608	X	399	X	15	1 PC
10	608	X	399	X	15	1 PC
11	938	X	400	X	15	1 PC
12	592	X	362	X	15	3 PCS
13	298	X	362	X	15	3 PCS

## HARDWARE LIST (1/1)

NO.	DESCRIPTION		QTY
A		WOOD DOWEL M8 x 25MM	24
B		CAM NUT	34
C		CAM BOLT	34
D		CAM CAP	34
E		CB SCREW M3.5 x 16MM	72
F		CB SCREW M4 x 32MM	24
G		CSK CAP WOOD M6 x 50MM	6
H		HANDLE SCREW M4 x 19MM	10
I		HANDLE 7050-96MM	5
J		ALLEN KEY M4	1
K		SHELF SUPPORT	24
L		PVC CORNER L-BRACKET	12
M		HINGES 7/8"	11
N		3MM PVH - 567MM	1
O		3MM PVH - 767MM	1
P		METAL ADJUST LEG	1

THE USE OF POWER TOOLS TO ASSEMBLE THIS PRODUCT WILL INVALIDATE ANY CLAIM AND MAY DAMAGE THIS PRODUCT MAKING IT UNSAFE.



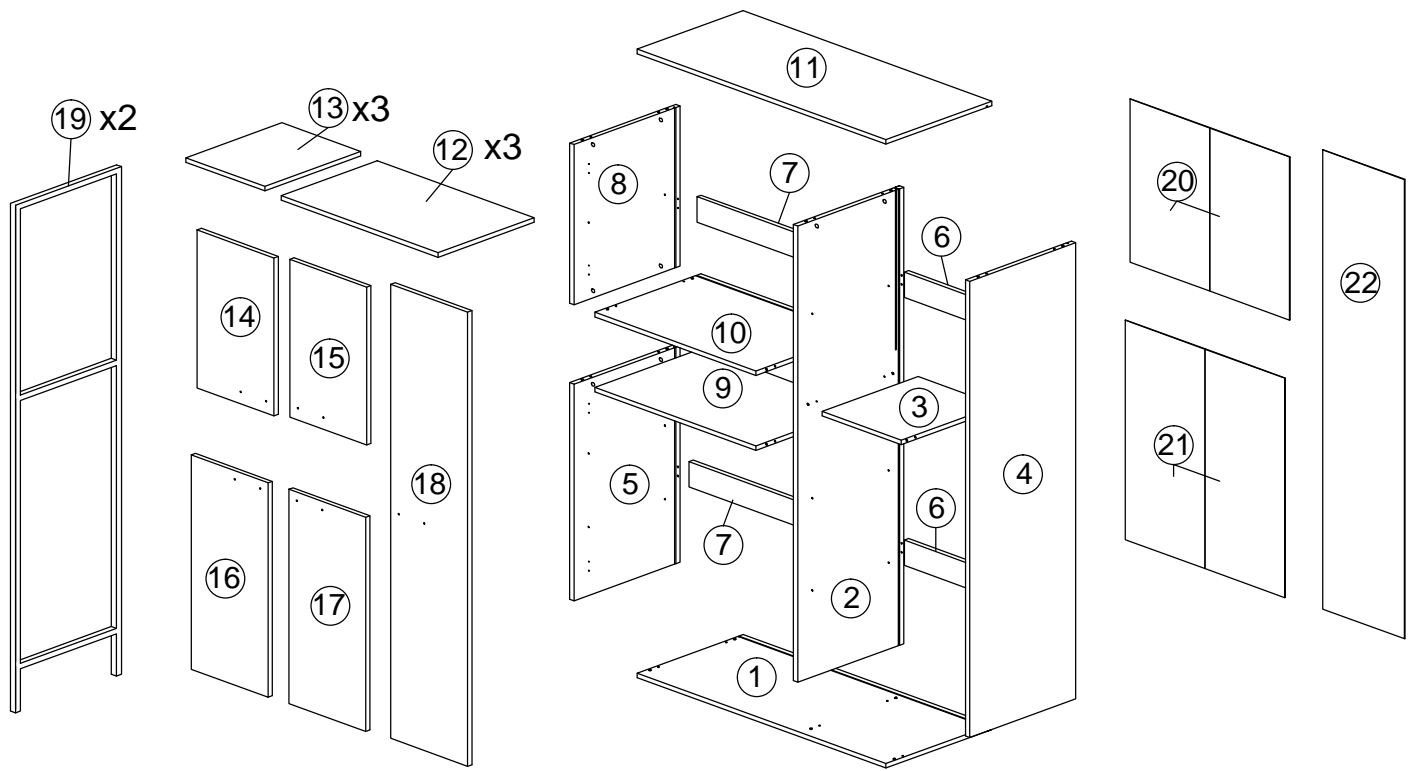

## PARTS LIST (2/2)

NO.	PARTS					QTY
14	558	X	288	X	15	1 PC
15	558	X	288	X	15	1 PC
16	758	X	288	X	15	1 PC
17	758	X	288	X	15	1 PC
18	1608	X	288	X	15	1 PC
19	1800	X	400	X	19	2 PCS
20	578	X	300	X	2.5	2 PCS
21	778	X	300	X	2.5	2 PCS
22	1628	X	308	X	2.5	1 PC

THE USE OF POWER TOOLS TO ASSEMBLE THIS PRODUCT WILL INVALIDATE ANY CLAIM AND MAY DAMAGE THIS PRODUCT MAKING IT UNSAFE.



# STEP 1

A	 WOOD DOWEL M8 x 25MM	24
---	--	----

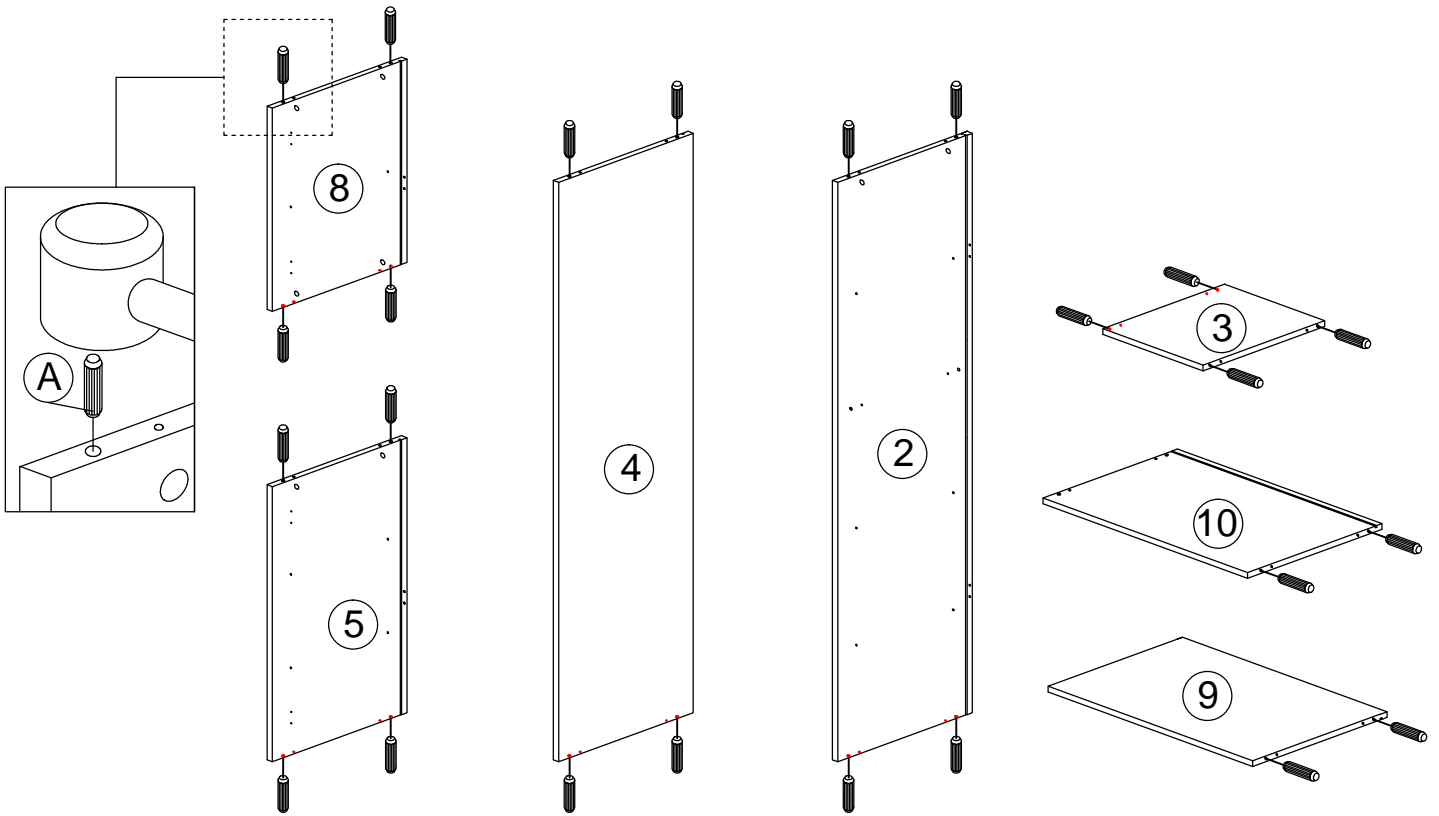

# STEP 2

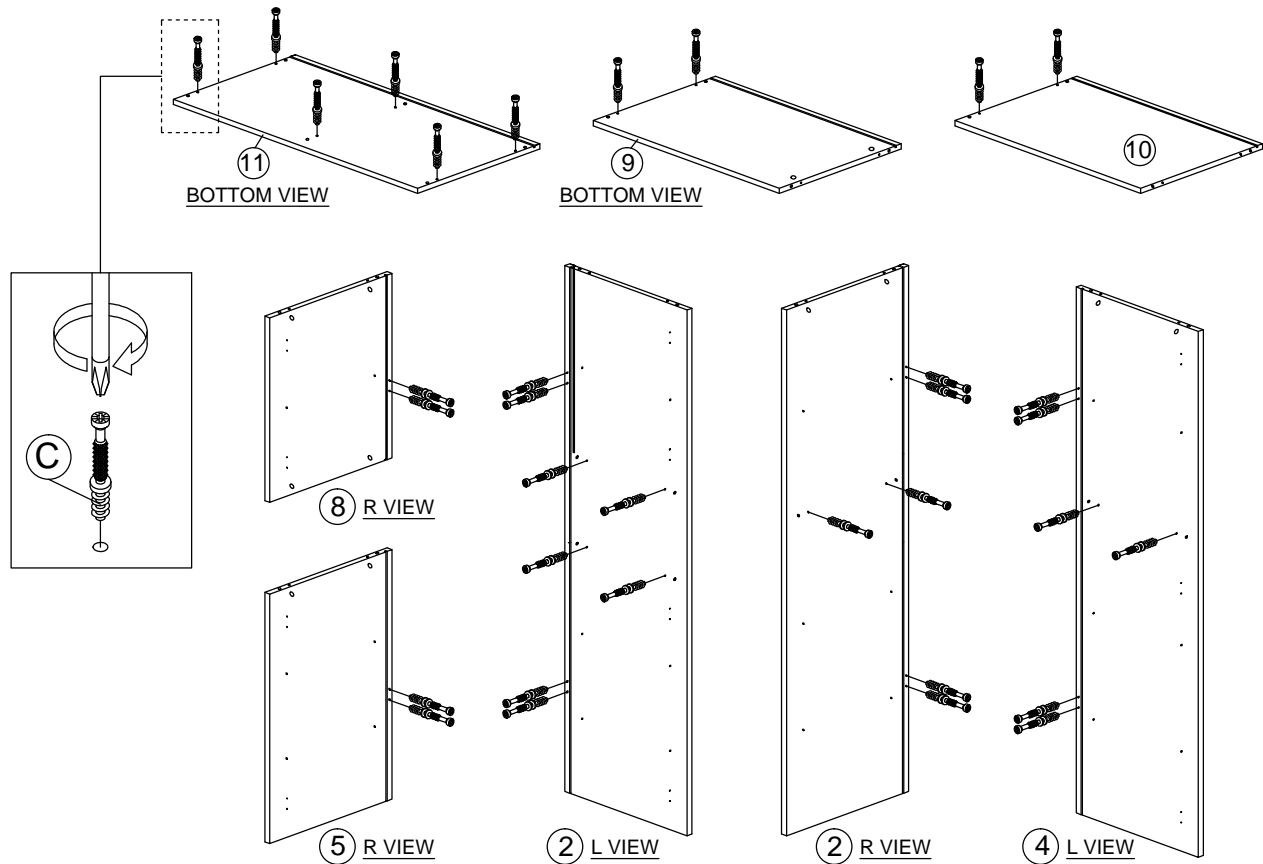

C	 CAM BOLT	34
---	--	----



THE USE OF POWER TOOLS TO ASSEMBLE THIS PRODUCT WILL INVALIDATE ANY CLAIM AND MAY DAMAGE THIS PRODUCT MAKING IT UNSAFE.



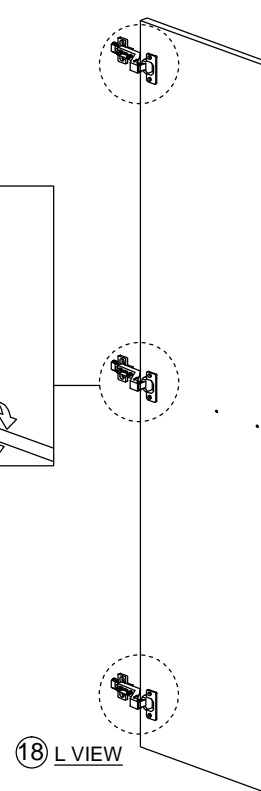
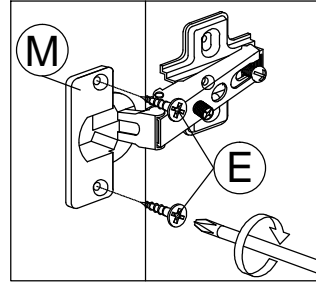
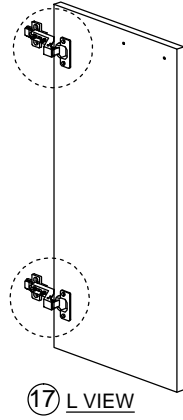
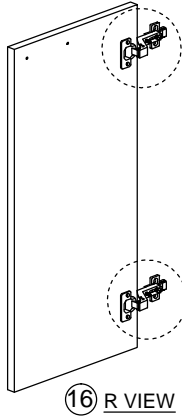
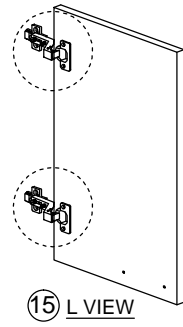
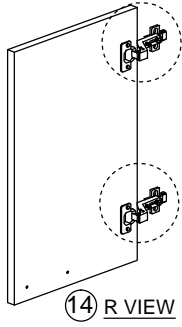

## STEP 3

E	 CB SCREW M3.5 x 16MM	22
M	 HINGES 7/8	11



## STEP 4

H	 HANDLE SCREW M4 x 19MM	10
I	 HANDLE 7050-96MM	5

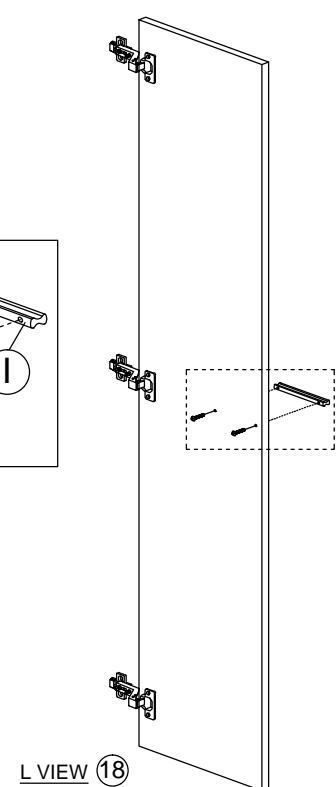
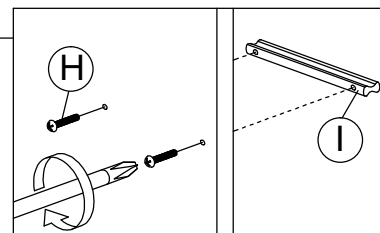
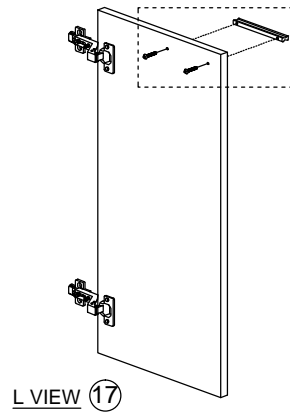
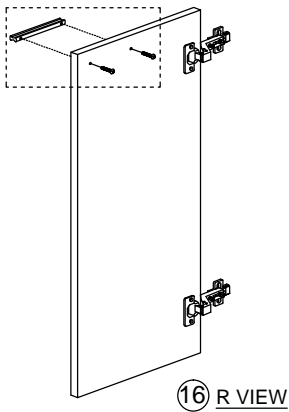
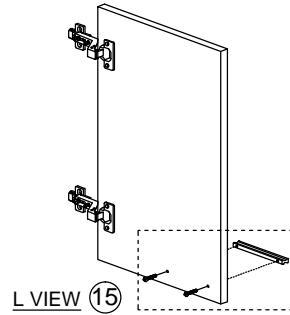
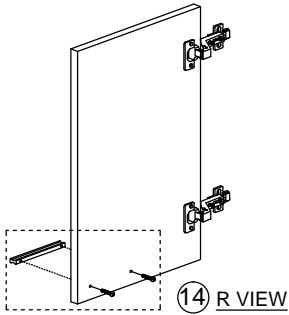

THE USE OF POWER TOOLS TO ASSEMBLE THIS PRODUCT WILL INVALIDATE ANY CLAIM AND MAY DAMAGE THIS PRODUCT MAKING IT UNSAFE.



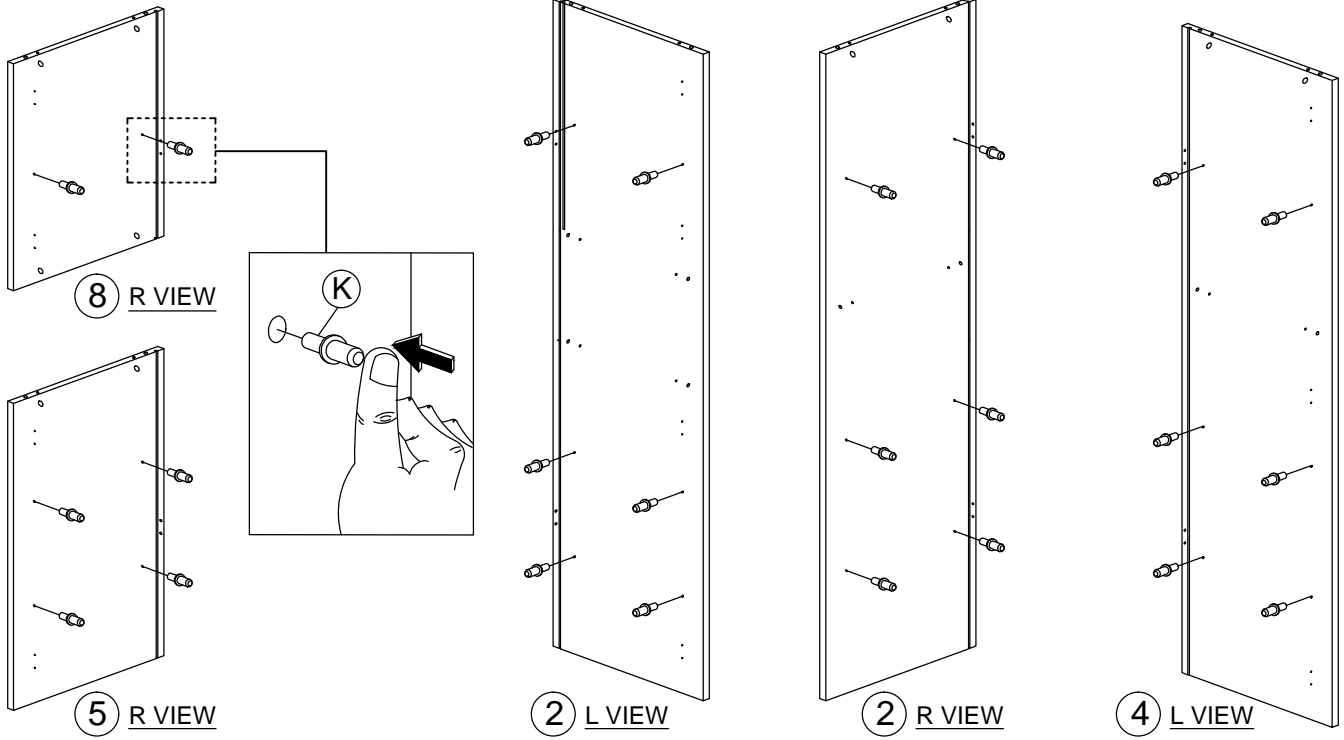

# STEP 5

K	 <b>SHELF SUPPORT</b>	24
---	---	----



# STEP 6

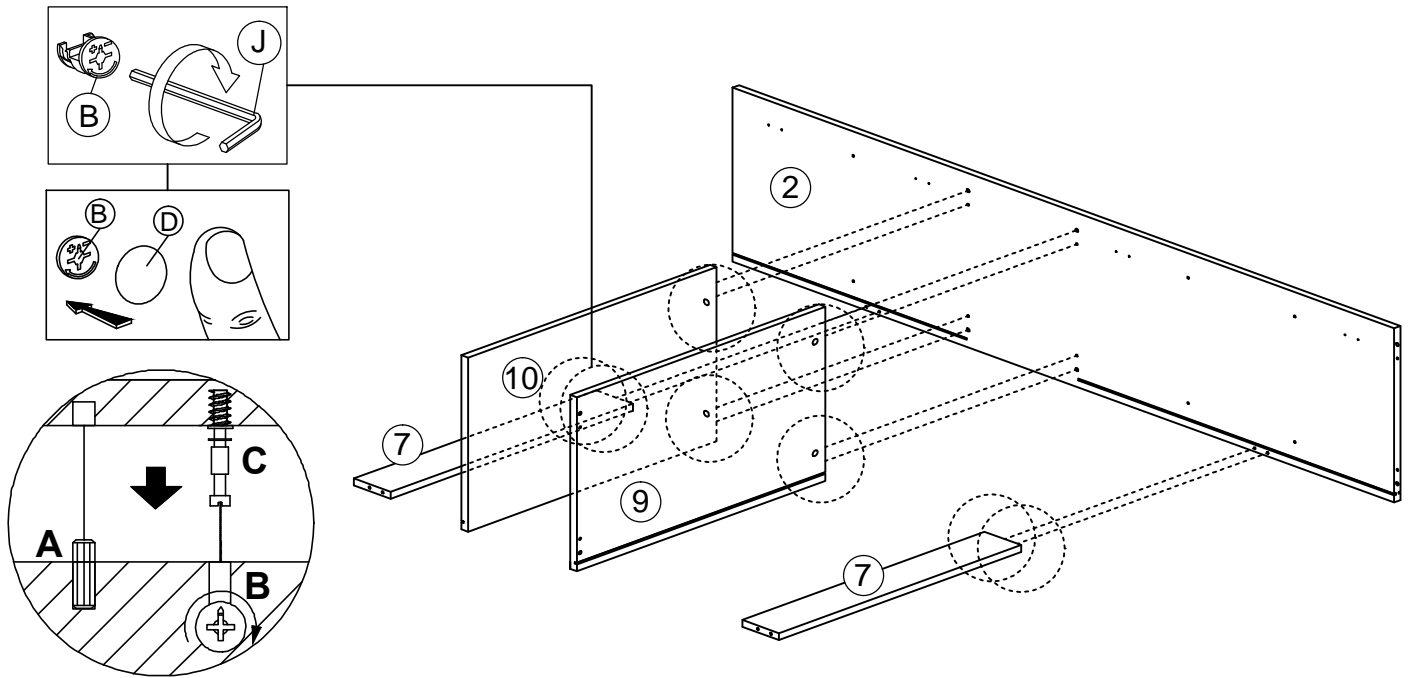

B	 <b>CAM NUT</b>	8
D	 <b>CAM LOCK</b>	8
J	 <b>ALLEN KEY M4</b>	1



**THE USE OF POWER TOOLS TO ASSEMBLE THIS PRODUCT WILL INVALIDATE ANY CLAIM AND MAY DAMAGE THIS PRODUCT MAKING IT UNSAFE.**



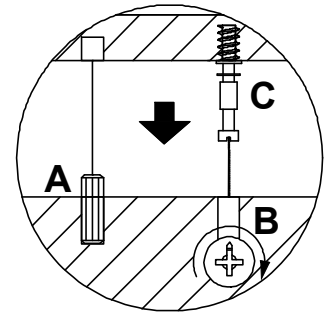
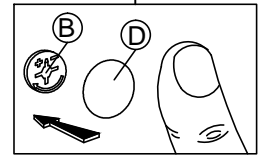
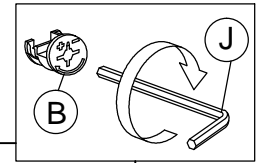
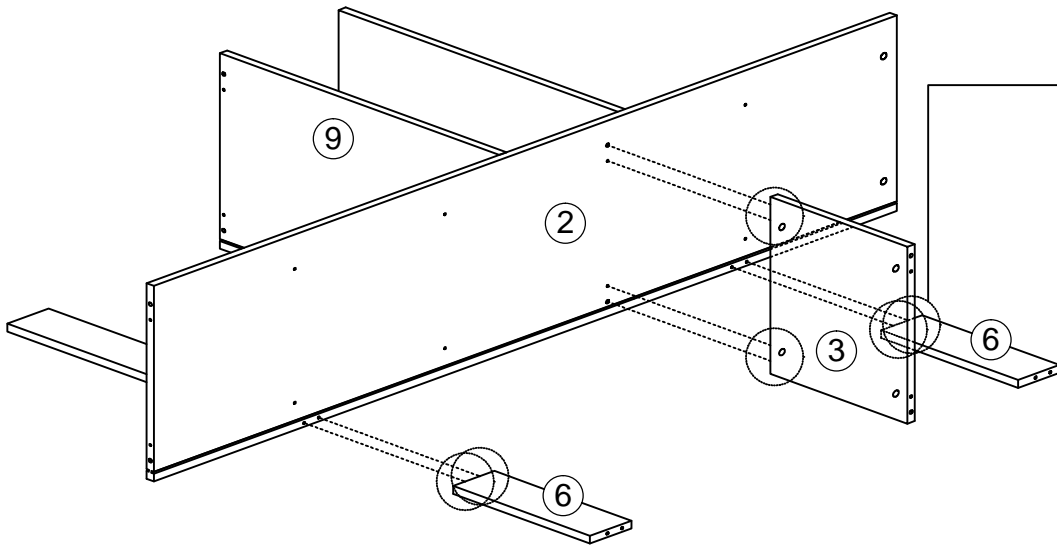

## STEP 7

B		CAM NUT	6
D		CAM LOCK	6
J		ALLEN KEY M4	1



## STEP 8

B		CAM NUT	6
D		CAM LOCK	6
J		ALLEN KEY M4	1

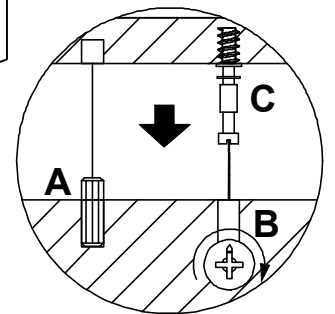
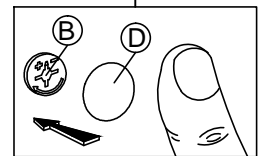
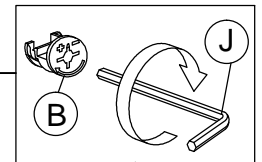
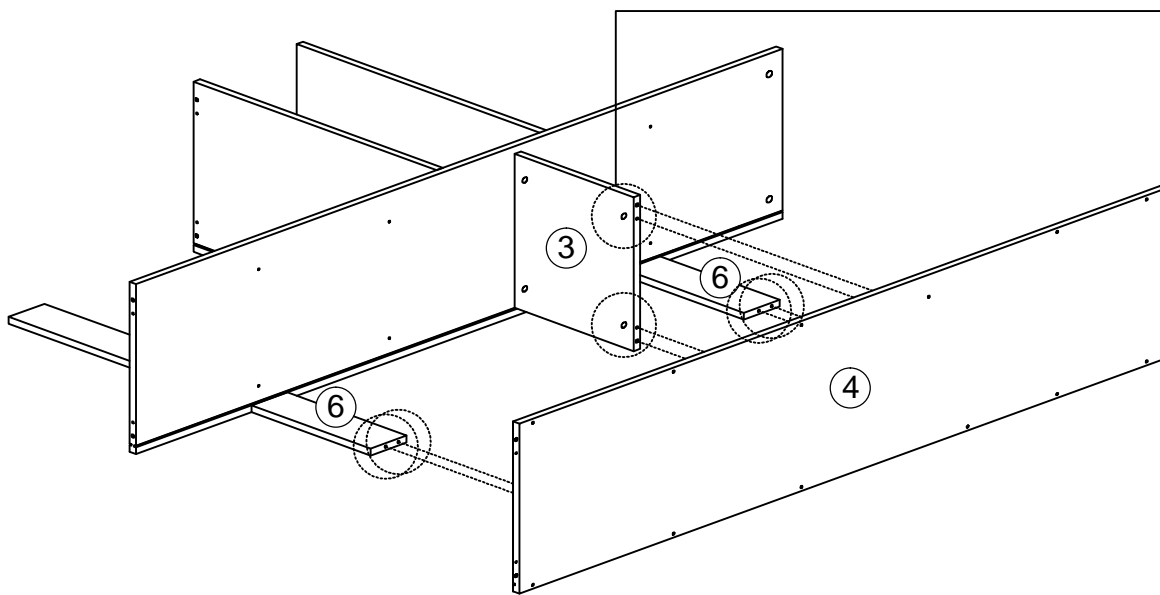



THE USE OF POWER TOOLS TO ASSEMBLE THIS PRODUCT WILL INVALIDATE ANY CLAIM AND MAY DAMAGE THIS PRODUCT MAKING IT UNSAFE.





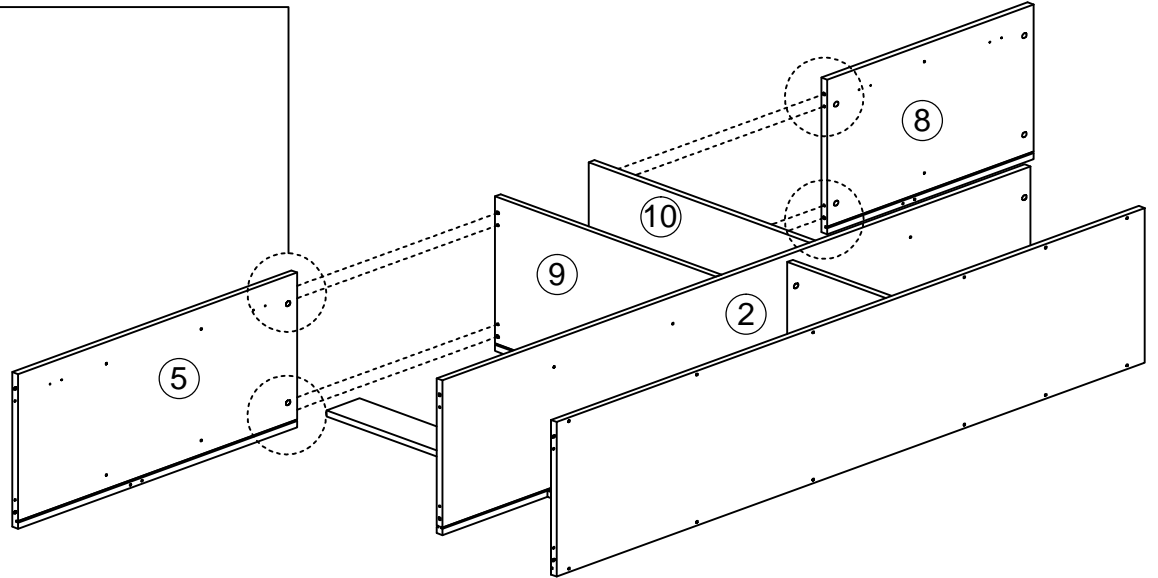
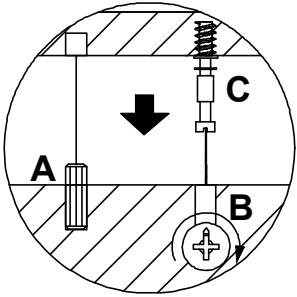
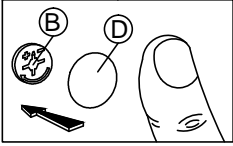
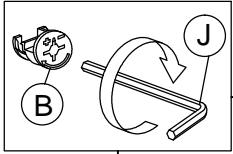

## STEP 9

B		CAM NUT	4
D		CAM LOCK	4
J		ALLEN KEY M4	1



## STEP 10

B		CAM NUT	4
D		CAM LOCK	4
J		ALLEN KEY M4	1

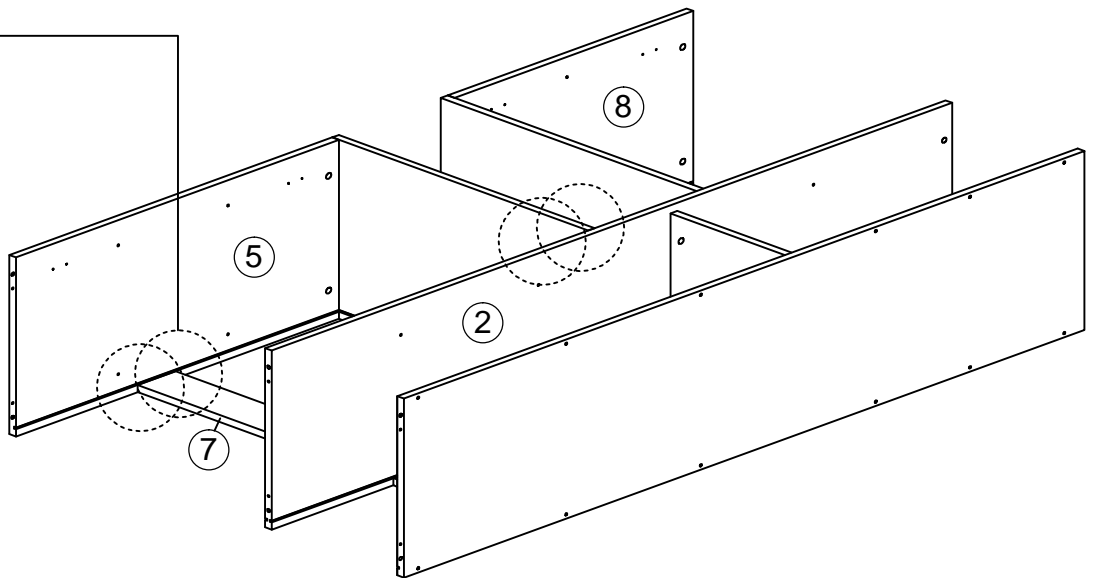
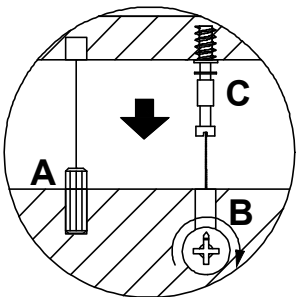
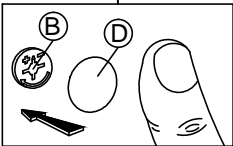
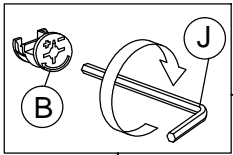

THE USE OF POWER TOOLS TO ASSEMBLE THIS PRODUCT WILL INVALIDATE ANY CLAIM AND MAY DAMAGE THIS PRODUCT MAKING IT UNSAFE.



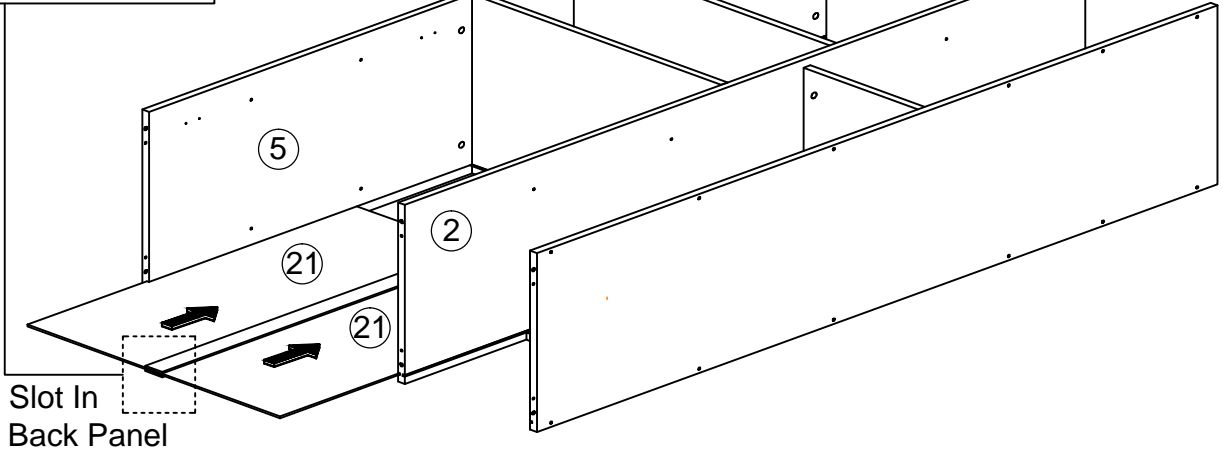
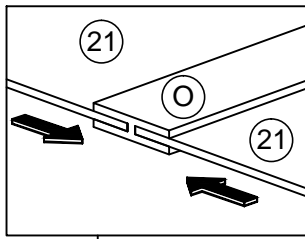

## STEP 11

O		PVH 3MM -767MM	1
---	--	----------------	---



## STEP 12

G		CSK CAP WOOD M6 x 50MM	6
J		ALLEN KEY M4	1

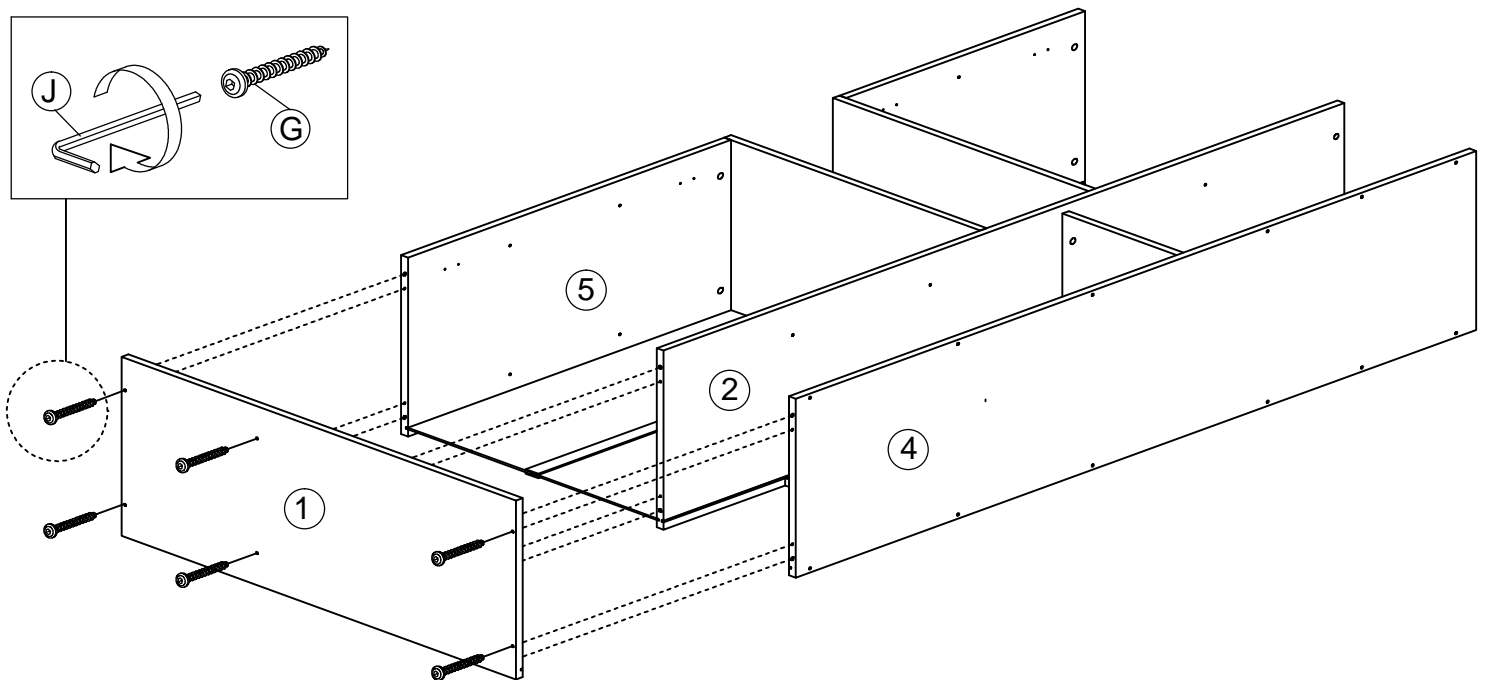
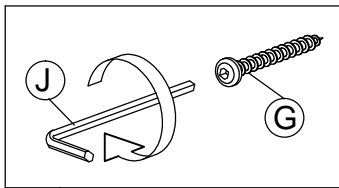

THE USE OF POWER TOOLS TO ASSEMBLE THIS PRODUCT WILL INVALIDATE ANY CLAIM AND MAY DAMAGE THIS PRODUCT MAKING IT UNSAFE.



# STEP 13

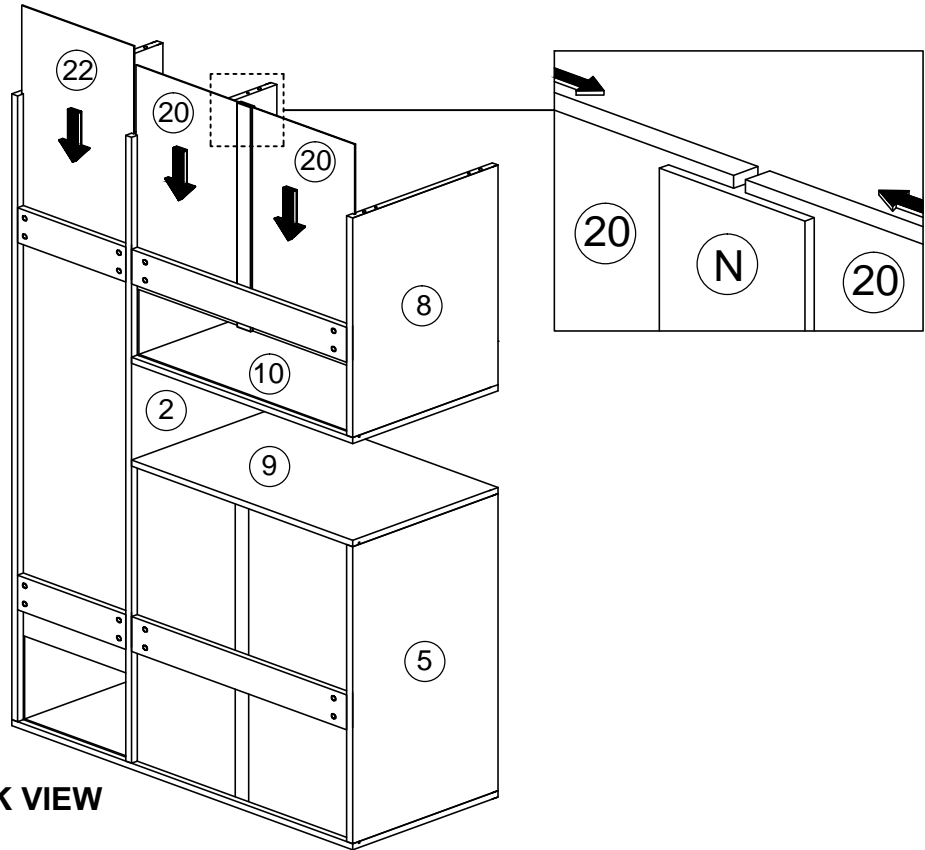

N		PVH 3MM -567MM	1
---	--	----------------	---

Slot In  
Back Panel



BACK VIEW

# STEP 14

B		CAM NUT	6
D		CAM LOCK	6
J		ALLEN KEY M4	1

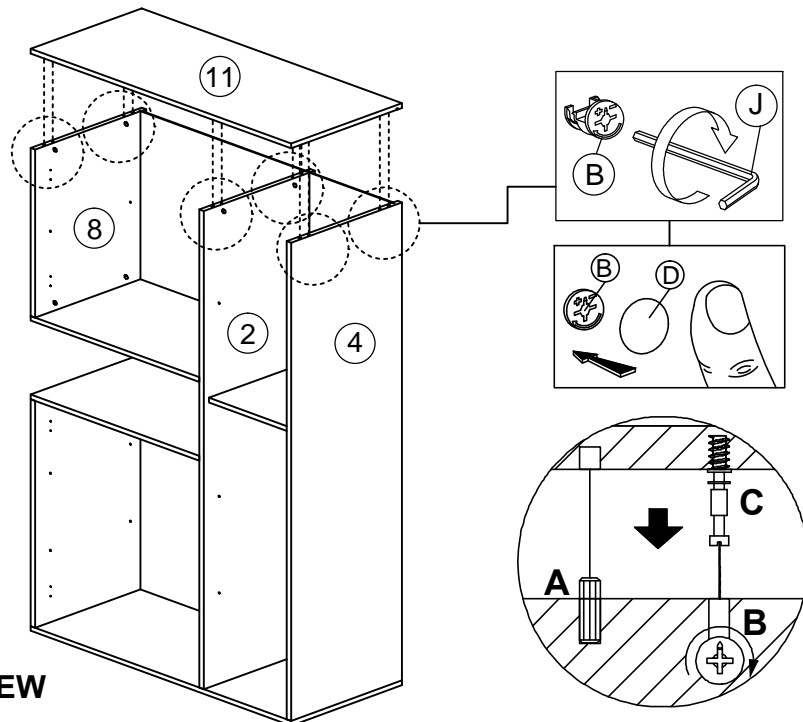

FRONT VIEW

THE USE OF POWER TOOLS TO ASSEMBLE THIS PRODUCT WILL INVALIDATE ANY CLAIM AND MAY DAMAGE THIS PRODUCT MAKING IT UNSAFE.



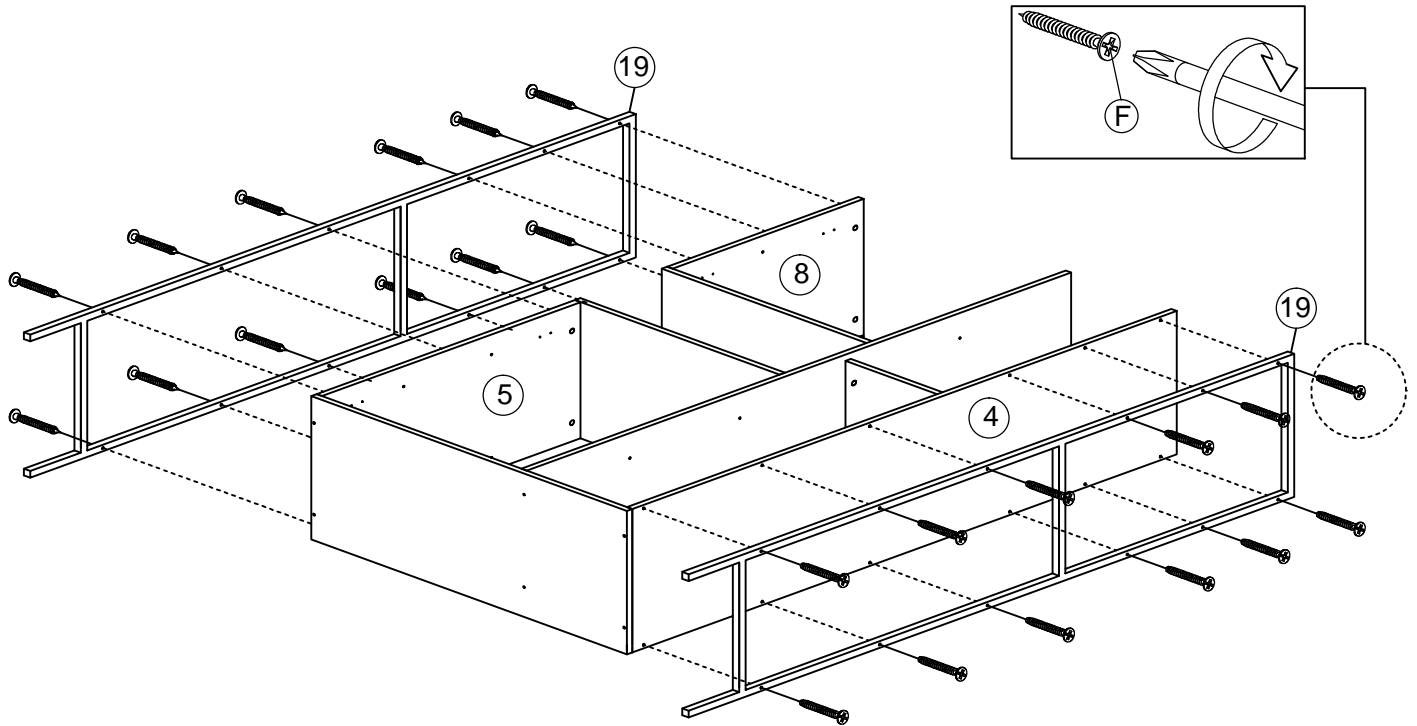

# STEP 15

F		CB SCREW M4 x 32MM	24
---	---	--------------------	----



# STEP 16

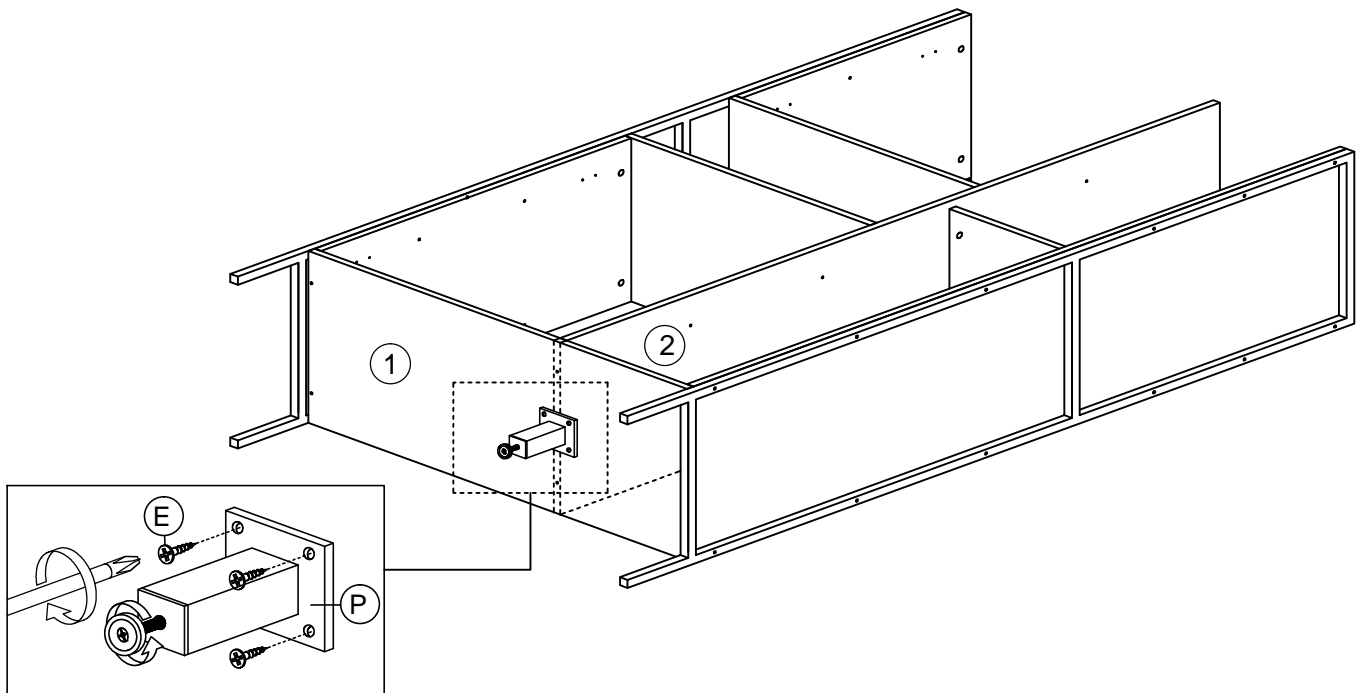

E		CB SCREW M3.5 x 16MM	4
P		METAL ADJUST LEG	1



THE USE OF POWER TOOLS TO ASSEMBLE THIS PRODUCT WILL INVALIDATE ANY CLAIM AND MAY DAMAGE THIS PRODUCT MAKING IT UNSAFE.



## STEP 17

E		CB SCREW M3.5 x 16MM	24
L		PVC CORNER L-BRACKET	12

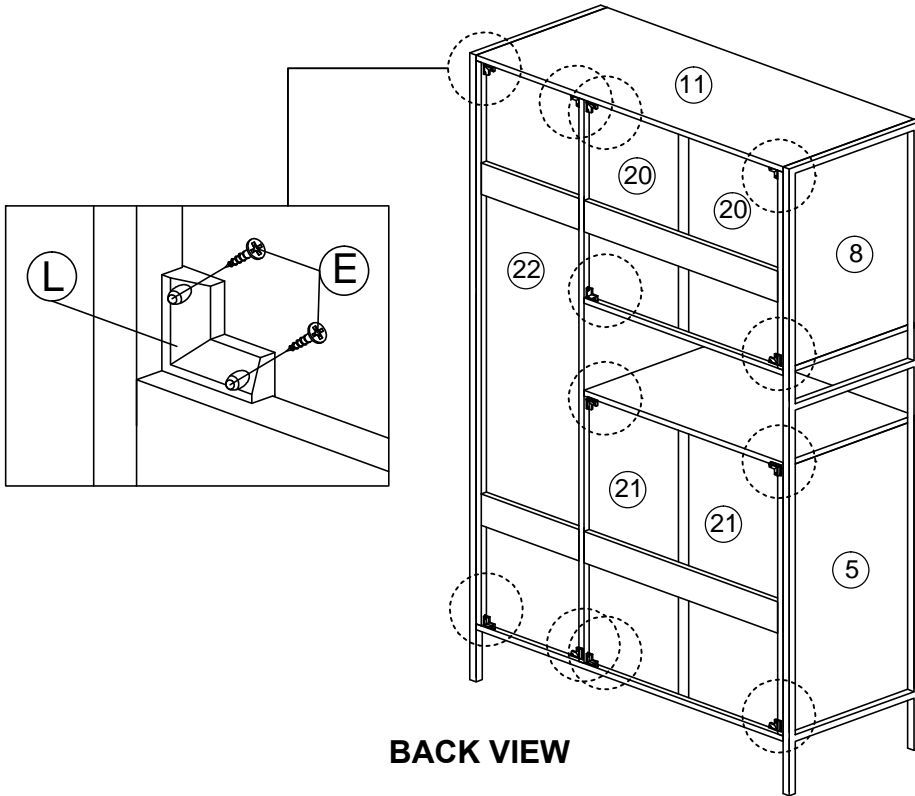

## STEP 18

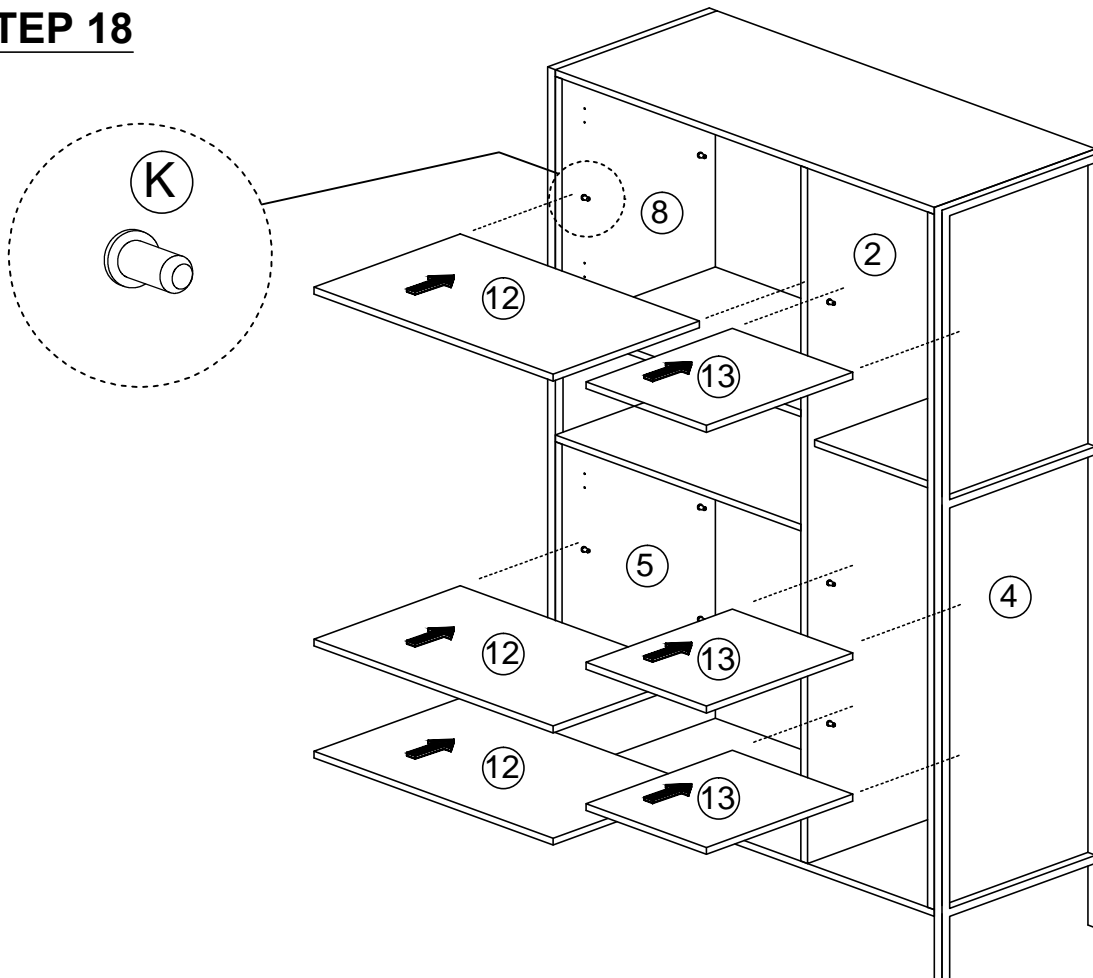

THE USE OF POWER TOOLS TO ASSEMBLE THIS PRODUCT WILL INVALIDATE ANY CLAIM AND MAY DAMAGE THIS PRODUCT MAKING IT UNSAFE.



# STEP 19

E	 CB SCREW M3.5 x 16MM	22
---	--	----

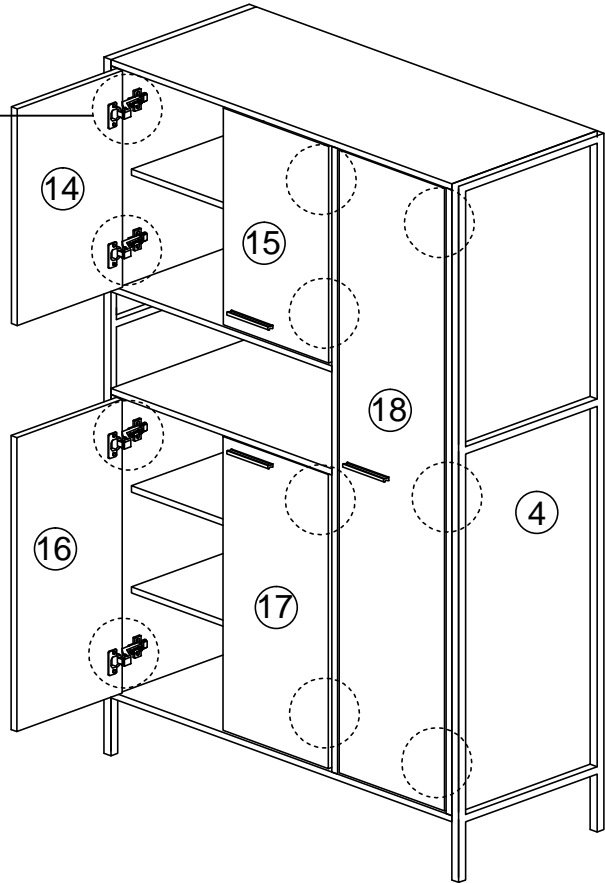
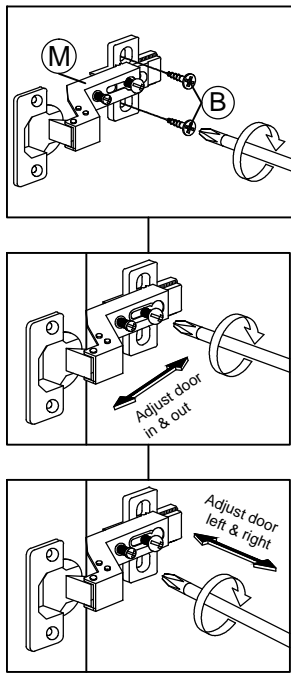

# COMPLETED

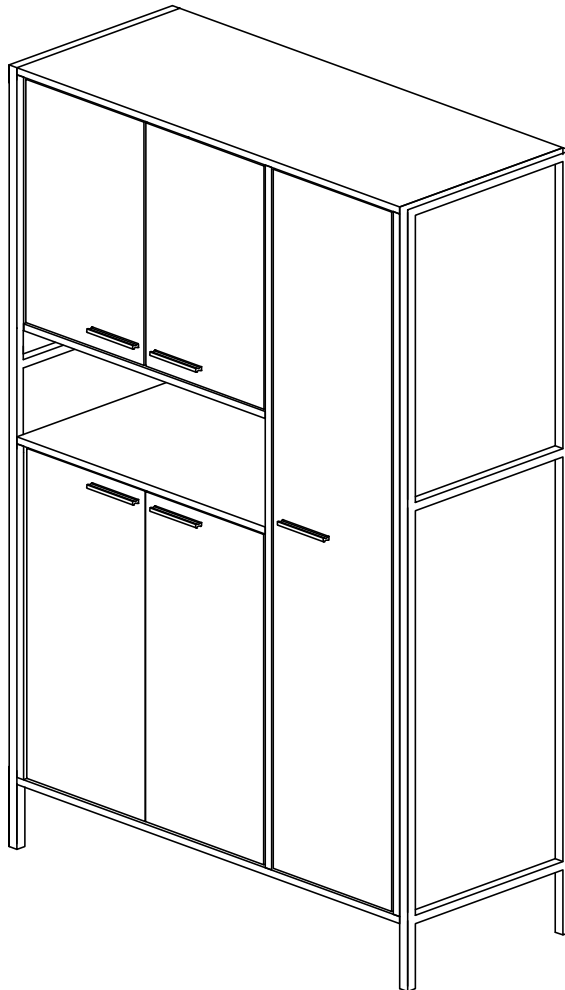

THE USE OF POWER TOOLS TO ASSEMBLE THIS PRODUCT WILL INVALIDATE ANY CLAIM AND MAY DAMAGE THIS PRODUCT MAKING IT UNSAFE.

